

Size	L	ΦD0	ΦD	ΦD1	ΦD2	ΦD3	n-Φd	b	H
10"	330	Φ254.6	Φ404.62	Φ314.96	Φ284.5	Φ355.6	8-Φ22	30.23	1185
12"	356	Φ304.8	Φ457.2	Φ368.3	Φ337.82	Φ412.75	8-Φ22	31.75	1375

*All dimensions are in millimeter.

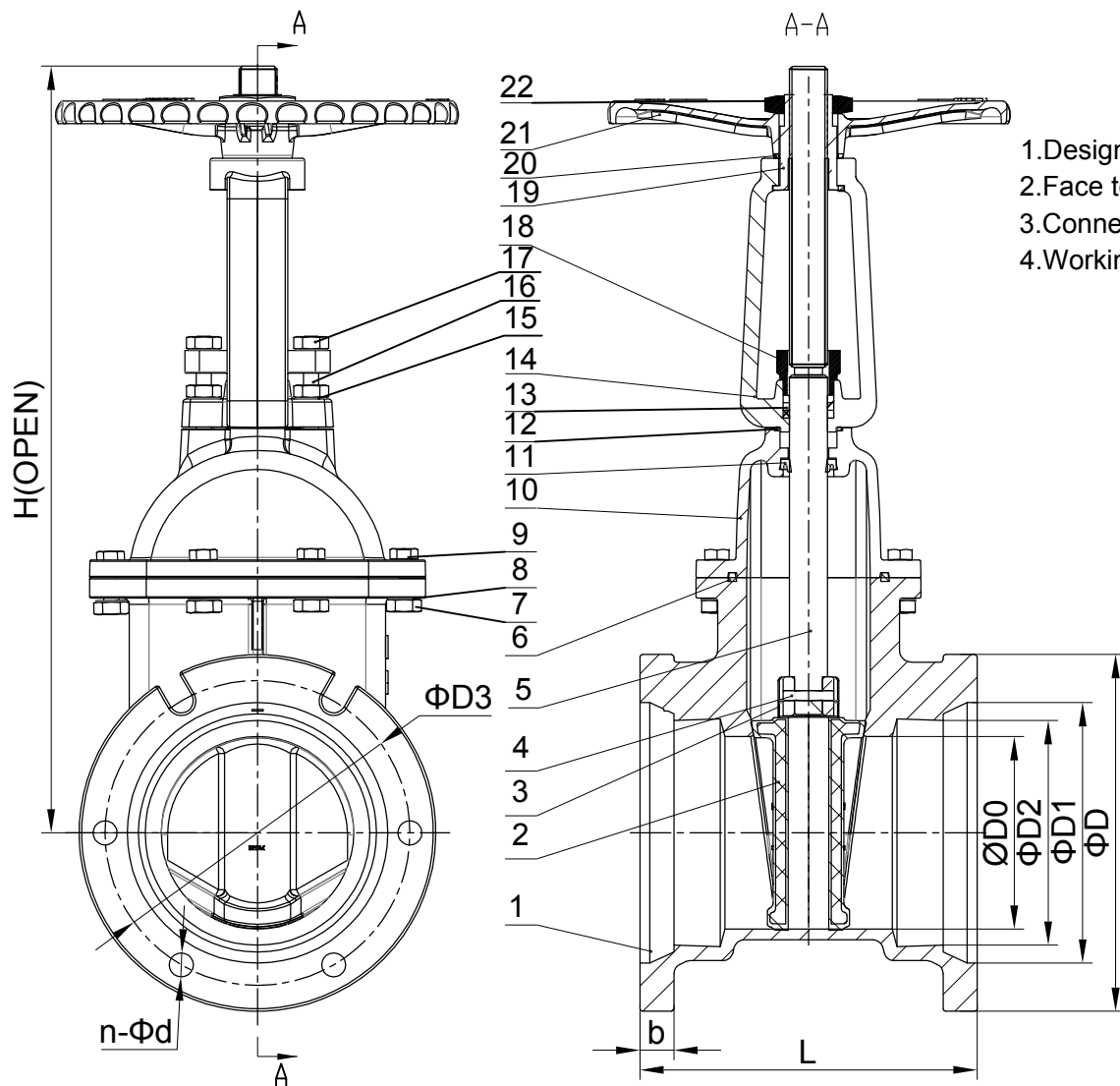

- 1.Design Standard/设计标准: AWWA C515 for 2"-8"; AWWA C509 for 10"-12".
- 2.Face to Face Standard/结构长标准: ANSI B16.10
- 3.Connection Ends/连接标准: AWWA C111/A21.11, AWWA C110
- 4.Working Pressure/工作压力: 175PSI, 200PSI, 250PSI, 300PSI

22	Thin Nut/薄螺母	Stainless Steel/不锈钢	ASTM A276 304
21	Handweel/手轮	Ductile Iron/球铁	A536 65-45-12
20	Washer/铜垫片	Aluminium Bronze/铝青铜	AS1565 C95210
19	Yoke Nut/支架螺母	Aluminium Bronze/铝青铜	AS1565 C95210
18	Gland/压盖	Ductile Iron/球铁	A536 65-45-12
17	Nut/螺母	galvanized steel/碳钢镀锌	A307 Q235-A
16	studs/双头螺柱	galvanized steel 10.9grade/碳钢镀锌 10.9级	A307 Q235-A
15	Washer/平垫片	galvanized steel/碳钢镀锌	A307 Q235-A
14	Yoke/支架	Ductile Iron/球铁	A536 65-45-12
13	Packing/填料环	EPDM/三元乙丙橡胶	ASTM D2000
12	O-Ring/O型圈	EPDM/三元乙丙橡胶	ASTM D2000
11	V-Ring/V型圈	EPDM/三元乙丙橡胶	ASTM D2000
10	Bonnet/阀盖	Ductile Iron/球铁	A536 65-45-12
9	Bolt/六角头螺栓	galvanized steel 10.9grade/碳钢镀锌 10.9级	A307 Q235-A
8	Washer/平垫片	galvanized steel/碳钢镀锌	A307 Q235-A
7	Nut/螺母	galvanized steel/碳钢镀锌	A307 Q235-A
6	Bonnet Gasket/中法兰密封垫	EPDM/三元乙丙橡胶	ASTM D2000
5	Stem/阀杆	Stainless Steel/不锈钢	ASTM A276 431/304/316
4	Pin/圆柱销	Stainless Steel/不锈钢	ASTM A276 304
3	Stem Nut/阀杆螺母	Aluminium Bronze/铝青铜	AS1565 C95210
2	Wedge/闸板	Ductile Iron Encapsulated with EPDM/球铁+三元乙丙橡胶	A536 65-45-12+EPDM
1	Body/阀体	Ductile Iron/球铁	A536 65-45-12
N0/序号	Name/名称	Material/材料	Specification/规范

DRN		WEIGHT		MATERIAL
CHK		SCALE		OS&Y MJ. x MJ. Gate Valve
APP		DATE		10"-12"

hiwa

CZ0036
Z3113UF-MM-10-12-Assembly-UL

REV 20171115-A

This document is the property of Huihua Valve Industry Co. Distribution of this document without the written consent of the owner is strictly forbidden. Failure to comply will incur a liability for damages.

http://www.hiwa.cn Website
sales@hiwa.cn Email

86 - 533 - 6077200 Phone
86 - 533 - 6077233 FAX

Huihua Valve Industry Co.
No.36 MinAn Road New Hi-Tech Industry
Zone Zibo Shandong China 255088 p.c